

NOVIN COMPOSITE



www.novincomposite.com



NC

Dimension sheets for Type D

FRP Pipework Components to DIN 16965 and DIN 16966

Novin Composite pipes and fittings in fiber glass-reinforced plastics with chemical resistant layer; Type D

Material and properties

Novin composite pipes feature a load-bearing filament wound laminate topped by a chemical resistant layer at least 2.5 mm thick. This system provides excellent chemical resistance combined with high mechanical strength, even at elevated temperatures. The pipe's low intrinsic weight and good strain deformation behavior make them easy to assemble and arrange.

The very smooth internal pipe surfaces provide extremely low hydraulic friction losses. The reactive resins and textile glass fibers used for our DIN type D pipes and fittings allow cost-effective combinations matched to the application concerned.

The resins used include vinyl ester resins, polyester resins based on bisphenol A, neopentyl glycol, isophthalic acids and HET acids.

The pipes and fittings are manufactured by filament winding using fiber glass textile products of quality grades E-glass, C-glass and E-CR glass and others.

Collars, slip-on flanges and blind flanges are available for flanged joints to ASME B16.5, class 150.

Project-specific pressure and size variants not listed here can be supplied on request.

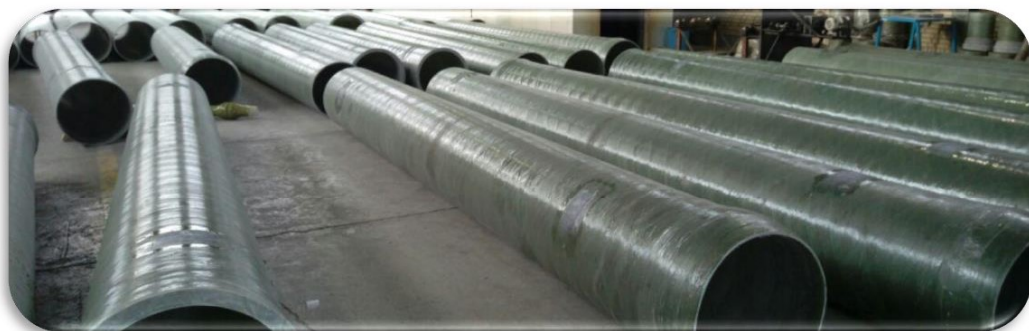

Winding laminate for pipes

Guide values for 20°C		
Tensile strength	circumferential	360 MPa
	axial	180 MPa
Modulus of elasticity	circumferential	17000 MPa
	axial	13000 MPa
Flexural strength	Circumferential	>360 MPa
	axial	>180 MPa
Modulus of elasticity, flexural	circumferential	>16000 MPa
	axial	>8500 MPa
Shear modulus	axial (bending)	3250 MPa
Thermal expansion coefficient	-	25 – 30 × 10 ⁻⁶ K ⁻¹
density	FRP	1800 Kg/m ³
Thermal conductivity	FRP	0.27 W/mK

Installation notes:

Guide values for distance between supports (m) for pipes without thermal insulation

Size (in)	DN (mm)	PN 10 (bar)				PN 16 (bar)			
		Gas	Liquids			Gas	Liquids		
		ρ _{fill} 0	ρ _{fill} 1	ρ _{fill} 1.5	ρ _{fill} 1.8	ρ _{fill} 0	ρ _{fill} 1	ρ _{fill} 1.5	ρ _{fill} 1.8
1	25	See PN16				2.3	2	2	1.9
1 ¼	32	See PN16				2.5	2.2	2.1	2
1 ½	40	See PN16				2.8	2.3	2.2	2.1
2	50	See PN16				3	2.5	2.3	2.3
2 ½	65	See PN16				3.4	2.7	2.5	2.5
3	80	See PN16				3.7	2.8	2.8	2.5
4	100	See PN16				4.1	3	2.9	2.7
5	125	See PN16				4.6	3.2	3.2	2.8
6	150	5	3.3	3.1	3	5.1	3.4	3.5	3
8	200	5.7	3.6	3.3	3.2	5.8	3.8	3.6	3.3
10	250	6.6	4	3.6	3.5	7	4.4	4.1	3.9
12	300	7.3	4.3	4	3.8	7.7	4.8	4.4	4.3
14	350	8.1	4.7	4.3	4.1	8.5	5.2	4.8	4.6
16	400	8.8	5	4.6	4.4	9.2	5.6	5.1	4.9
20	500	10	5.6	5.1	4.9	10.5	6.3	5.7	5.5
24	600	11	6.2	5.5	5.4	11.5	6.9	6.2	6

Pipes to DIN 16965 – Part4

Size (in)	DN (mm)	S4 (mm)	
		PN 10 (bar)	PN 16 (bar)
1	25		4.4
1 ¼	32		4.4
1 ½	40		4.4
2	50		4.4
2 ½	65		4.4
3	80		4.4
4	100		4.4
5	125		4.4
6	150	4.4	4.6
8	200	4.4	5.3
10	250	5.7	6
12	300	5.1	6.6
14	350	5.5	7.3
16	400	5.9	8
20	500	6.8	9.3
24	600	7.6	10.7
28	700	8.4	12
32	800	9.3	13.4
36	900	10.1	14.8
40	1000	11	16.1

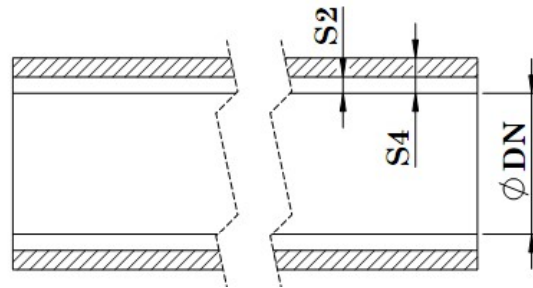

S2 is wall thickness of chemical-resistant layer, min. 2.5 mm

Application range to DIN 16867

Nominal pressure – PN (bar)	Service temperature	
	-20 to 50 °C	over 50 to 80 °C
	Permitted pressure – PS (bar g)	
16	16	10
10	10	6
6	6	4

Recommended loading for components installed in pipe systems is 70-95 % of the maximum of permitted pressure - PS

Elbows to DIN 16966 - Part2

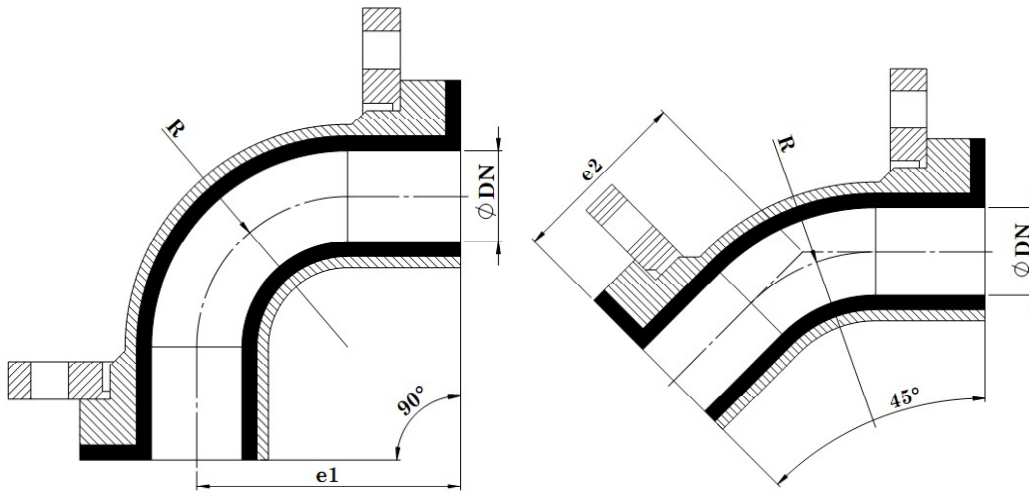

Size (in)	DN (mm)	e1 (mm) ELBOW 90°	e2 (mm) ELBOW 45°
1	25	110	70
1 ¼	32	130	80
1 ½	40	150	90
2	50	180	105
2 ½	65	140	85
3	80	165	100
4	100	205	115
5	125	245	135
6	150	285	150
8	200	365	190
10	250	450	225
12	300	525	260
14	350	600	290
16	400	680	325
20	500	830	390
24	600	950	430
28	700	1100	490
32	800	1250	545
36	900	1400	605
40	1000	1500	660

Tee and branches to DIN 16966 - Part4

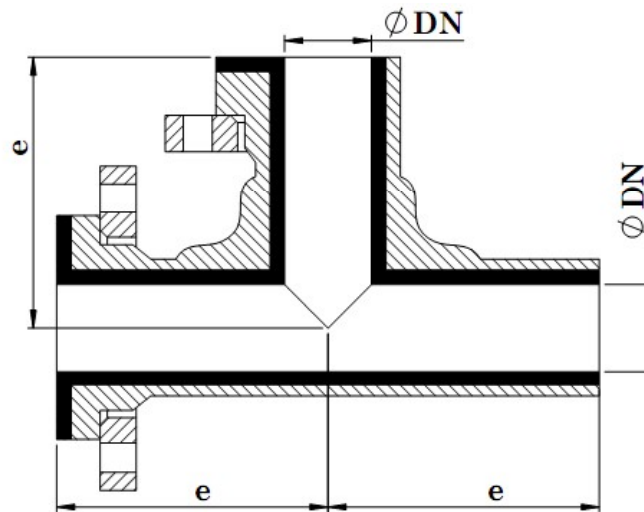

Size (in)	DN (mm)	e (mm)
1	25	110
1 ¼	32	130
1 ½	40	150
2	50	180
2 ½	65	140
3	80	165
4	100	205
5	125	245
6	150	285
8	200	365
10	250	450
12	300	525
14	350	600
16	400	680
20	500	830
24	600	950
28	700	1100
32	800	1250
36	900	1400
40	1000	1500

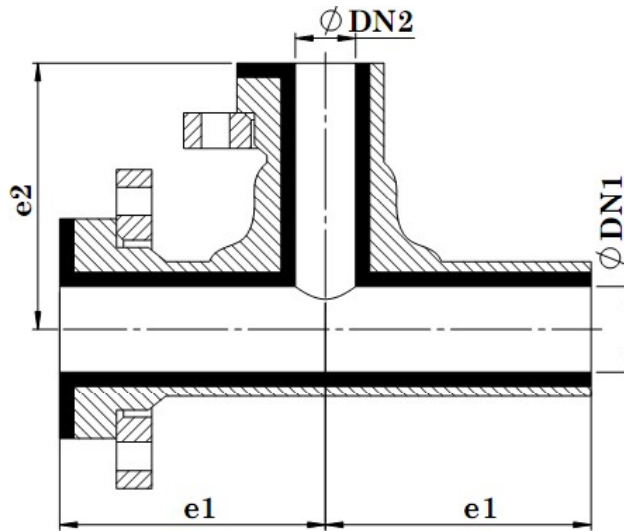

RUN		BRANCH		e1 (mm)	e2 (mm)
Size (in)	DN1 (mm)	Size (in)	DN2 (mm)		
1 ¼	32	1	25	130	170
1 ½	40	1	25	150	175
		1 ¼	32		
2	50	1	25	180	180
		1 ¼	32		
		1 ½	40		
2 ½	65	1 ¼	32	140	190
		1 ½	40		
		2	50		
3	80	1 ½	40	165	195
		2	50		
		2 ½	65		
4	100	2	50	205	205
		2 ½	65		
		3	80		
5	125	2 ½	65	245	270
		3	80		
		4	100		
6	150	3	80	285	240
		4	100		240
		5	125		290
8	200	4	100	365	260
		5	125		310
		6	150		310
10	250	5	125	450	340
		6	150		
		8	200		

RUN		BRANCH		e1 (mm)	e2 (mm)
Size (in)	DN1 (mm)	Size (in)	DN2 (mm)		
12	300	6	150	525	360
		8	200		365
		10	250		415
14	350	8	200	600	395
		10	250		445
		12	300		445
16	400	10	250	680	470
		12	300		470
		14	350		520
20	500	12	300	830	525
		14	350		575
		16	400		575
24	600	14	350	950	620
		16	400		620
		20	500		670
28	700	16	400	1000	675
		20	500		725
		24	600		750
32	800	20	500	1250	775
		24	600		800
		28	700		800
36	900	24	600	1400	850
		28	700		
		32	800		
40	1000	28	700	1500	905
		32	800		
		36	900		

Concentric and Eccentric reducers to DIN 16966 - Part5

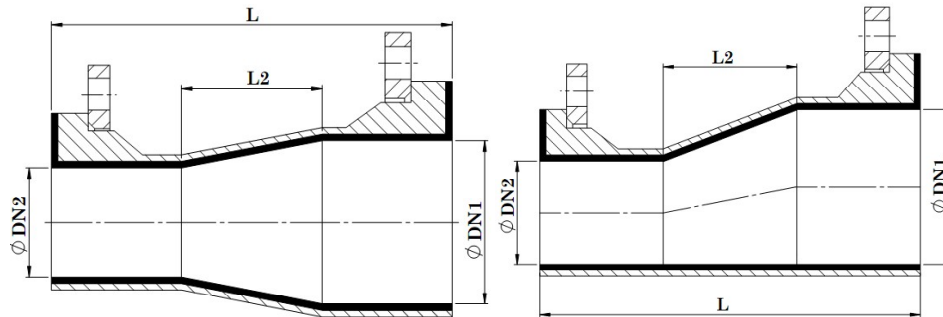

Size1 (in)	DN1 (mm)	Size 2 (in)	DN2 (mm)	L (mm)
1 ¼	32	1	25	180
1 ½	40	1	25	205
		1 ¼	32	200
2	50	1	25	235
		1 ¼	32	230
		1 ½	40	205
2 ½	65	1 ¼	32	260
		1 ½	40	235
		2	50	210
3	80	1 ½	40	275
		2	50	245
		2 ½	65	210
4	100	2	50	325
		2 ½	65	285
		3	80	250
5	125	2 ½	65	350
		3	80	310
		4	100	285
6	150	3	80	375
		4	100	350
		5	125	310
8	200	4	100	495
		5	125	430
		6	150	370
10	250	5	125	575
		6	150	510
		8	200	400

Size1 (in)	DN1 (mm)	Size2 (in)	DN2 (mm)	L (mm)
12	300	6	150	655
		8	200	540
		10	250	435
14	350	8	200	665
		10	250	550
		12	300	440
16	400	10	250	695
		12	300	580
		14	350	450
20	500	12	300	865
		14	350	730
		16	400	615
24	600	14	350	980
		16	400	865
		20	500	630
28	700	16	400	1160
		20	500	930
		24	600	660
32	800	20	500	1160
		24	600	910
		28	700	665
36	900	24	600	1185
		28	700	945
		32	800	700
40	1000	28	700	1220
		32	800	975
		36	900	735

And L2(mm) is:

$$L2 = (DN1 - DN2) \times 2.5$$

Loos and fixed flanges to DIN 2501 PN10

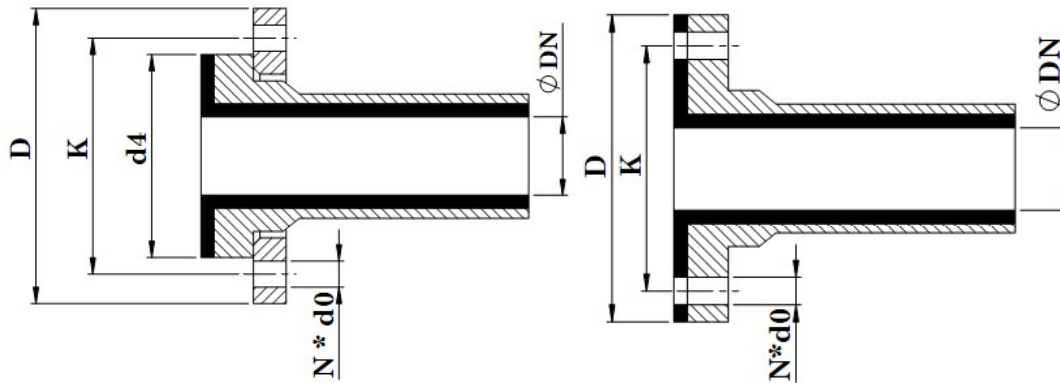

Size (in)	DN (mm)	D (mm)	K (mm)	d4 (mm)	N	d0 (mm)	Bolts size
1	25	115	85	68	4	14	M12
1 ¼	32	140	100	78	4	18	M16
1 ½	40	150	110	88	4	18	M16
2	50	165	125	102	4	18	M16
2 ½	65	185	145	122	4	18	M16
3	80	200	160	138	8	18	M16
4	100	220	180	158	8	18	M16
5	125	250	210	188	8	18	M16
6	150	285	240	212	8	22	M20
8	200	340	295	268	8	22	M20
10	250	395	350	320	12	22	M20
12	300	445	400	370	12	22	M20
14	350	505	460	430	16	22	M20
16	400	565	515	482	16	26	M24
20	500	670	620	585	20	26	M24
24	600	780	725	685	20	30	M27
28	700	895	840	800	24	30	M27
32	800	1015	950	905	24	33	M30
36	900	1115	1050	1005	28	33	M30
40	1000	1230	1160	1110	28	36	M33

Loos and fixed flanges to ASME B16.5 & ASME B16.47 CLASS 150

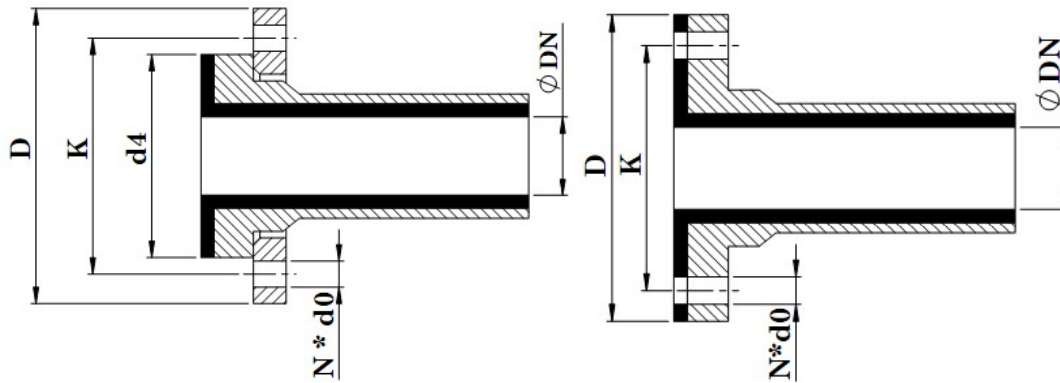

Size (in)	DN (mm)	D (mm)	K (mm)	d4 (mm)	N	d0 (mm)	Bolts size
1	25	108	79.2	61	4	15.7	1/2 "
1 ¼	32	117	88.9	72	4	15.7	1/2 "
1 ½	40	127	98.6	82	4	15.7	1/2 "
2	50	152	120.7	100	4	19.1	5/8 "
2 ½	65	178	139.7	119	4	19.1	5/8 "
3	80	190	152.4	132	4	19.1	5/8 "
4	100	229	190.5	170	8	19.1	5/8 "
5	125	254	215.9	188	8	22.4	3/4 "
6	150	279	241.3	216	8	22.4	3/4 "
8	200	343	298.5	270	8	22.4	3/4 "
10	250	406	362	324	12	25.4	7/8 "
12	300	483	431.8	381	12	25.4	7/8 "
14	350	533	476.3	420	12	28.5	1 "
16	400	597	539.8	476	16	28.5	1 "
20	500	698	635	585	20	31.8	9/8 "
24	600	813	749.3	692	20	35.1	5/4 "

Blank flange with thermoplastics liners

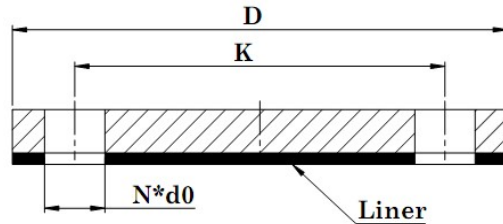

Size (in)	DN (mm)	DIN 16966 -Part6				ASME B16.5 CLASS 150			
		D (mm)	K (mm)	N	d0 (mm)	D (mm)	K (mm)	N	d0 (mm)
1	25	115	85	4	14	108	79.2	4	15.7
1 ¼	32	140	100	4	18	117	88.9	4	15.7
1 ½	40	150	110	4	18	127	98.6	4	15.7
2	50	165	125	4	18	152	120.7	4	19.1
2 ½	65	185	145	4	18	178	139.7	4	19.1
3	80	200	160	8	18	190	152.4	4	19.1
4	100	220	180	8	18	229	190.5	8	19.1
5	125	250	210	8	18	254	215.9	8	22.4
6	150	285	240	8	22	279	241.3	8	22.4
8	200	340	295	8	22	343	298.5	8	22.4
10	250	395	350	12	22	406	362	12	25.4
12	300	445	400	12	22	483	431.8	12	25.4
14	350	505	460	16	22	533	476.3	12	28.5
16	400	565	515	16	26	597	539.8	16	28.5
20	500	670	620	20	26	698	635	20	31.8
24	600	780	725	20	30	813	749.3	20	35.1
28	700	895	840	24	30				
32	800	1015	950	24	33				
36	900	1115	1050	28	33				
40	1000	1230	1160	28	36				

Application range to DIN 16867

Nominal pressure – PN (bar)	Nominal diameter – DN (mm)	Service temperature	
		-20 to 50 °C	over 50 to 80 °C
		Permitted pressure – PS (bar g)	
16	25 to 50	16	10
10	65 to 150	10	6
6	200 to 300	6	4
4	350 to 500	4	2.5
2.5	600 to 1000	2.5	1.6

Recommended loading for components installed in pipe systems is 70-95 % of the maximum of permitted pressure - PS

Laminated joint to DIN 16966 - Part8

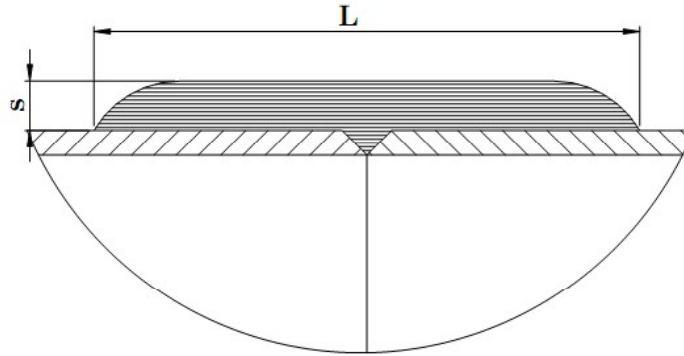

Size	PN10		PN16	
	S (mm)	L (mm)	S (mm)	L (mm)
1			4	110
1 ¼			4	110
1 ½			4	110
2			4	110
2 ½	4	110	4.5	110
3	4	110	5	120
4	4	110	6.5	140
5	5	110	8	175
6	6	130	9.5	210
8	8	165	13	280
10	10	205	16	345
12	11.5	250	19	415
14	13.5	290	22	460
16	15.5	330	25	550
20	19.5	410	31.5	685
24	23	480	38	745
28	27	560	44	880
32	31	640	50	990
36	35	720	57	1115
40	39	795	63	1235



Novin Composite Sadra

Producer of composite parts in Aerospace , Oil Gas , and Petrochemical industries
Supplier of raw material in composite industries

No. 321B, 3rd of Kooshesh St., technologies industrial state, Mashhad, Iran

Tel : +9851 - 32400110 - 18

Fax : +9851 - 32400119

www.novincomposite.com

